



**Gwneud iddo Ddigwydd**

**Making it Happen**

Dr Bryan Griffiths  
Marie Latham-Jones  
Gwenllian Owen

**Arloesi neu Beidio**

**Innovation or Not**



**Arloesi neu Beidio**

**Innovation or Not**



# Arloesi neu Beidio

## Innovation or Not

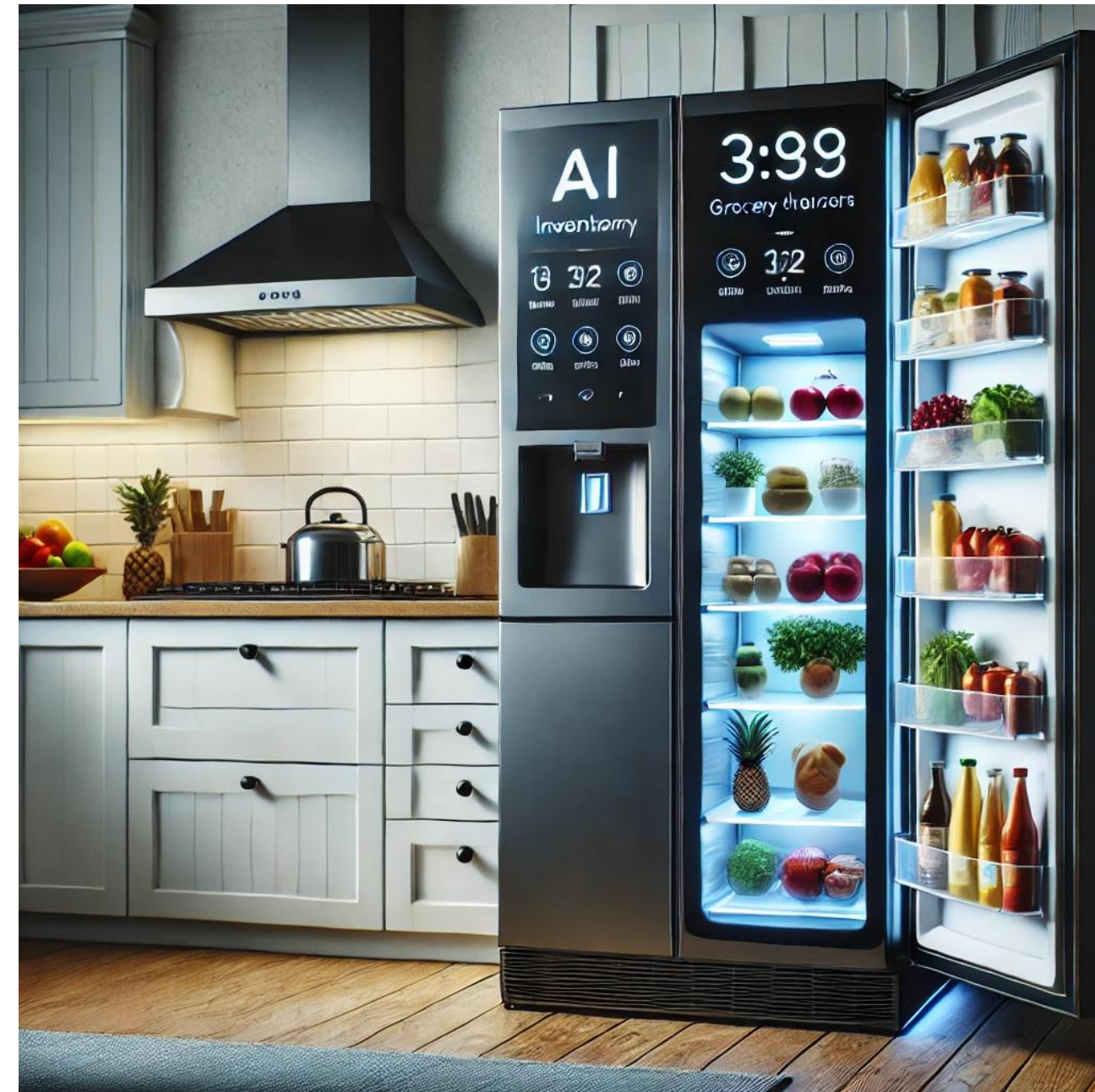

# Arloesi neu Beidio Innovation or Not



**Arloesi neu Beidio**

**Innovation or Not**



**Arloesi neu Beidio**

**Innovation or Not**





GIG  
CYMRU  
NHS  
WALES

Bwrdd Iechyd Prifysgol  
Betsi Cadwaladr  
University Health Board

# Fframwaith Arloesi Cymru Gyfan Ymchwil a Datblygu BIPBC

## The All Wales Innovation framework BCUHB Research & Development



# Health & Social Care Innovation Wales: Innovation Framework



## Cross Cutting Resources and Support

Funding & Grants

Advice & Mentorship

Programmes and Initiatives

Tools, Guides & Templates

Training & Development

Knowledge Management & Information Sharing

Facilities, Buildings, & Workplaces

## Strategic Enablers

Innovation Strategy & Delivery Plan

IP & Commercialisation Policy

Governance & Decision Making Guidance

Strategic Partnerships & Collaboration

Data, Insight & Intelligence

Finance & Procurement

Leadership and Culture

Building Capacity & Capability

Standards, Competency Frameworks & Certification

Assets Mapping & Gap Analysis



GIG  
CYMRU  
NHS  
WALES

Bwrdd Iechyd Prifysgol  
Betsi Cadwaladr  
University Health Board

### Scenario 1 – Develop Solutions

You have a new product in early development and need clinical/operational input

### Scenario 2 – Develop Solutions

You have a pre regulatory product and need help with developing the product and securing regulatory compliance in the UK

### Scenario 3 – Creating evidence and proving value

You have a post regulatory approval product and need help creating evidence and proving value, and gaining insights in to product deployment and change in the UK market.

### Scenario 4 – Spread and Scale

You have a well established product and need support to access Health & Social Care



# IECHYD A MWY HEALTH +



TANIO SYNIADAU AM DDYFODOL IACH  
EMPOWERING IDEAS FOR A HEALTHIER FUTURE



Llywodraeth Cymru  
Welsh Government

Canolfan  
Technoleg  
**OpTIC**  
Technology  
Centre



gan Brifysgol Bangor  
by Bangor University



**GIG**  
CYMRU  
**NHS**  
WALES

Bwrdd Iechyd Prifysgol  
Betsi Cadwaladr  
University Health Board

Cefnogaeth Arloesol ar gyfer Sectorau  
Iechyd, Gwyddorau Bywyd a Gofal  
Cymdeithasol Gogledd Cymru.

Innovative Support for the Health, Life  
Science & Social Care Sector in North Wales.



I gefnogi syniadau newydd o fewn y sector Iechyd a Gofal Cymdeithasol trwy sesiynau ysbrydoledig gyda arbenigwyr, buddsoddwyr a mwy.

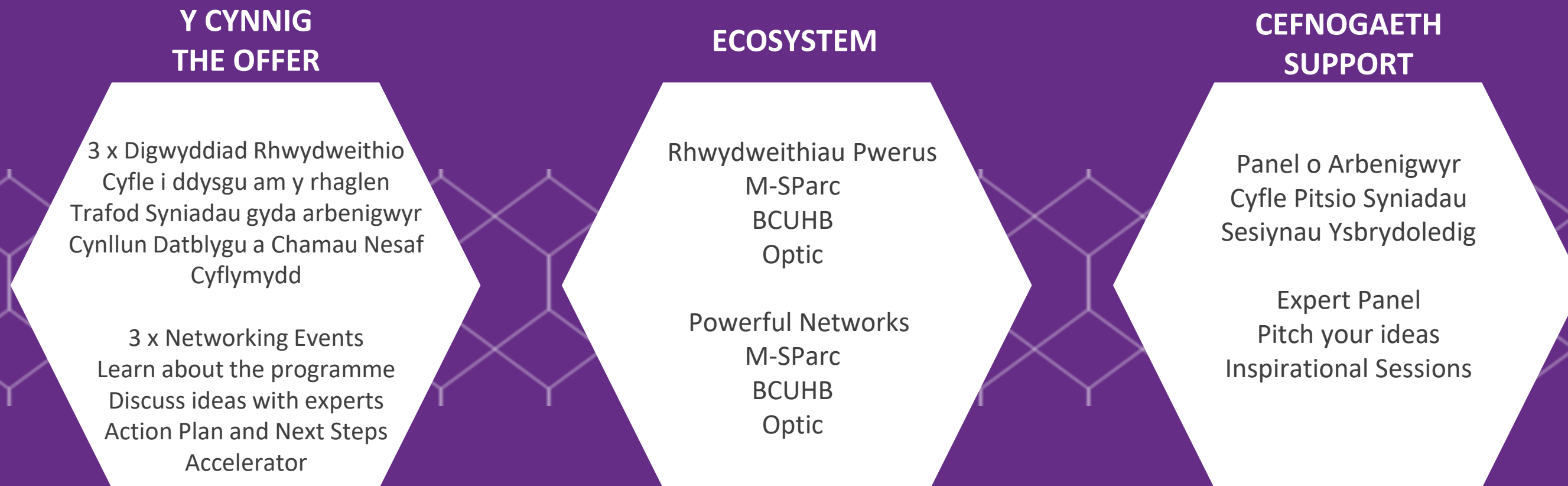

To support the development of new ideas in the Health and Social Care sector through inspirational sessions, experts, investors and more.

# IECHYD A MWY – DIGWYDDIAD TANIO SYNIADAU

## HEALTH+ - IDEATION EVENT

### CYFLWYNO PRESENTING

- Trafod eich syniad hefo panel o arbenigwyr
  - Cynllun Gweithredu
- Discuss your ideas with a panel of specialists
  - Action Plan

*Pecyn Cymorth / Toolkit*

*Cynllun Gweithredu/Action Plan*

### PWY? WHO?

Panel profiadol:  
Cefndir: Diwydiant, Busnes Cymru,  
Prifysgol, Arbenigwyr Sector

---

Experienced Panel  
Background: Industry, Business  
Wales, University,  
Sector Specialists.

*Mynediad at arbenigwyr / access to experts*

### CANLYNIAD RESULTS

- Cyfle i ddatblygu eich syniad
- Pitsio i Banel o Arbenigwyr
  - Dosbarthiadau Meistr
- 
- Develop your idea
- Pitch to a Panel of Experts
  - Masterclasses

*Byrbennu: Trafodaeth gyda ymgynghorwyr profiadol*

*Triage: Discussion with experienced advisers*

## Y BWRDD NA ALLWCH EI FFORDDIO THE BOARD YOU CAN'T AFFORD

- Bwrdd o Arbenigwyr o sectorau Diwydiant, Bwrdd Iechyd a Buddsoddwyr
- Mynediad at Ddosbarthiadau Meistr yn cael eu cyflwyno gan Arbenigwyr
- A Board of Experts from Industry, Health Boards and Investors
- Access to Masterclasses delivered by Experts

# IECHYD A MWY

## HEALTH +



TANIO SYNIADAU AM DDYFODOL IACH  
EMPOWERING IDEAS FOR A HEALTHIER FUTURE



Llywodraeth Cymru  
Welsh Government

Canolfan  
Technoleg  
**OpTIC**  
Technology  
Centre



gan Brifysgol Bangor  
by Bangor University



**GIG**  
CYMRU  
**NHS**  
WALES

Bwrdd Iechyd Prifysgol  
Betsi Cadwaladr  
University Health Board



# Stori Llwyddiant Arloesedd – “Gofal ac Ymateb”

## An Innovation Success Story – “*Care & Respond*”

James.Ingram@Scienap.com  
Science & Engineering Application Ltd

## Ond yn gyntaf... Arloesi heb feddwl?

Sut i osod tyrbin gwynt nacelle 500 tonnell ar dŵr 100m+ o uchder (yn hirach na chae pêl-droed) yn y môr.

- Defnyddiwch y craen mwyaf yn y byd sydd wedi'i osod ar gwch sy'n costio £300,000+/diwrnod.
- Tynnwch y tŵr a lleoli'r offer trwm ar y gwaelod (tyrbin echelin fertigol) - "dim-brainer".
- Tynnwch y craen a dringo'r tŵr gydag uned codi symudol bach (gan ddefnyddio clamp ffrithiant syml).

## But first... A "no-brainer" innovation?

How to install a 500 tonne wind turbine nacelle on a tower 100m+ high (longer than a football pitch) in the sea.

- Use the biggest crane in the world mounted on a boat costing £300,000+/day.
- Remove the tower and locate the heavy equipment on the base (a vertical axis turbine) – a "no-brainer".
- Remove the crane and climb the tower with a small mobile lifting unit (using a simple friction clamp).

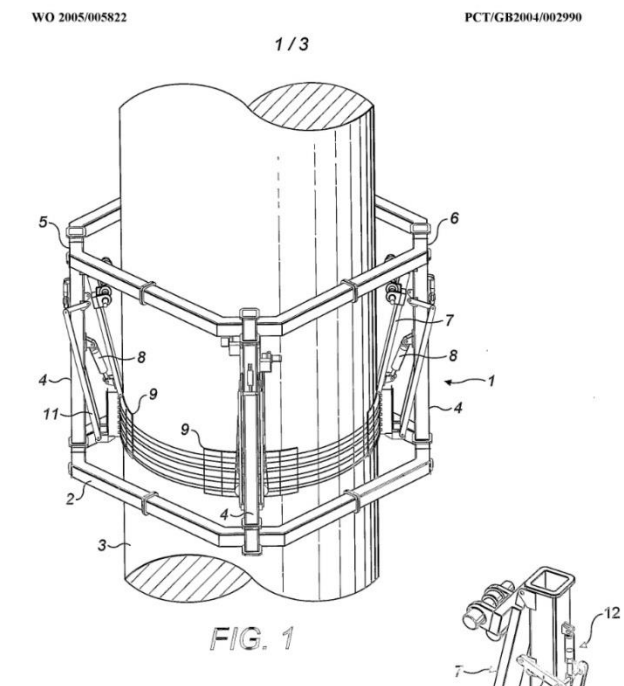

## Fy nysgu

1. Chwiliwch am y rhwystrau – diogelwch, hyfforddiant, technegol, masnachol, gwleidyddol ac ati, a pheidiwch â'u hanwybyddu.
2. Mae'n bosibl nad eich syniad "di-feddwl" mawr yw eich arloesedd ond yn hytrach yr ateb(ion) i oresgyn y rhwystrau i newid.
3. Gall ymagwedd "y cyfan neu ddim" eich gadael heb ddim.
4. Mewn digidol, gall newidiadau cynyddrannol fod yn gyflym ac yn aml.

## My Learning

1. Find the barriers – safety, training, technical, commercial, political etc., and don't ignore them.
2. Your innovation may not be your big "no-brainer" idea but rather the solution(s) to overcome the barriers to change.
3. An "all or nothing" approach can leave you with nothing.
4. In digital, incremental changes can be fast and frequent.

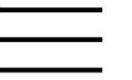

Home / [KoalaLifter](#)

## About

**The most efficient & flexible wind craneless system of the industry**

Y system heb graen gwynt mwyaf effeithlon a hyblyg yn y diwydiant

## Ynglŷn â Care & Respond

Set o apiau iechyd a gofal digidol a ddefnyddir gan unigolion a'u FFRINDIAU, TEULU a CHYMDOGION; gyda'r gallu i gysylltu â gwasanaethau cymorth proffesiynol:

- Cyflogwyr
- Elusennau a Gwasanaethau Gwirfoddoli
- Gwasanaethau Cymdeithasol
- Ysbytai
- Rheoli Ambiwllans
- Negeseuon Iechyd Cyhoeddus

Mae'n ddeiliant o Haciau Iechyd a Gofal Cymdeithasol 2022 a ariennir gan Lywodraeth Cymru: "Rwyf wrth fy modd bod yr ap Gofal ac Ymateb yn cael ei ddatblygu..." Eluned Morgan, pan oedd y Gweinidog dros Iechyd a Gwasanaethau Cymdeithasol

## About Care & Respond

A set of digital health and care apps used by individuals and their FRIENDS, FAMILY and NEIGHBOURS; with the ability to connect to professional support services:

- Employers
- Charities and Volunteer services
- Social Services
- Hospitals
- Ambulance Control
- Public Health messaging

It is a spin out from the Welsh Government funded Health and Social Care Hacks 2022: "I am delighted the Care and Respond app is being developed ..." Eluned Morgan, when Health and Social Services Minister



GIG  
CYMRU  
NHS  
WALES

Ymddiriedolaeth GIG  
Gwasanaethau Ambiwllans Cymru  
Welsh Ambulance Services  
NHS Trust



GIG  
CYMRU  
NHS  
WALES

Bwrdd Iechyd Prifysgol  
Betsi Cadwaladr  
University Health Board



GIG  
CYMRU  
NHS  
WALES

Bwrdd Iechyd Prifysgol  
Caerdydd a'r Fro  
Cardiff and Vale  
University Health Board



GIG  
CYMRU  
NHS  
WALES

Grŵp Gweithredu  
Afiechydon Prin  
Rare Diseases  
Implementation Group



GIG  
CYMRU  
NHS  
WALES

Bwrdd Iechyd Prifysgol  
Cwm Taf Morgannwg  
University Health Board

**cwmpas**



## Ceisiadau Care and Respond

Mae'n offeryn cydweithio sy'n galluogi gofalwyr di-dâl a gwasanaethau proffesiynol i drosoli'r gefnogaeth barod yn y gymuned i helpu unigolyn ag anghenion heb eu diwallu. Mae'n cefnogi gofal hynod bersonol ac yn hwyluso ymateb wedi'i gynllunio a heb ei gynllunio (gan gynnwys brys).

Mae agweddau ar y dechnoleg yn cynnwys:

- Proffil personol am unigolyn a'i gyflwr(au), dewisiadau ac anghenion;
- Ap larwm sy'n cael ei ysgogi â llaw neu'n awtomatig - y gellir ei gysylltu â dyfeisiau trydydd parti (dyfeisiau meddygol, larymau tân, drws ffrynt ac ati);
- Offer rheoli ymateb ar gyfer unigolion a sefydliadau;
- Paru proffil personol â gwybodaeth sefyllfaol a chyd-destunol i ddarparu hyfforddiant a chyngor "Yn y Foment" yn y swydd (i weithwyr proffesiynol a phobl leyg).

## Care & Respond applications

It is a collaboration tool that enables unpaid carers and professional services to leverage the willing support in the community to help an individual with unmet needs. It supports highly personalised care and facilitates planned and unplanned (inc. emergency) response.

Aspects of the technology include:

- A personal profile about an individual and their condition(s), preferences and needs;
- An alarm app triggered manually or automatically – connectable to 3<sup>rd</sup> party devices (medical devices, fire alarms, front door etc);
- Response management tools for individuals and organisations;
- Matching a personal profile with situational and contextual information to provide on the job "In the Moment" training and advice (for professionals and lay people).

Mae gennym ni fynyddoedd i'w symud ac mae angen i ni weithio'n smart.

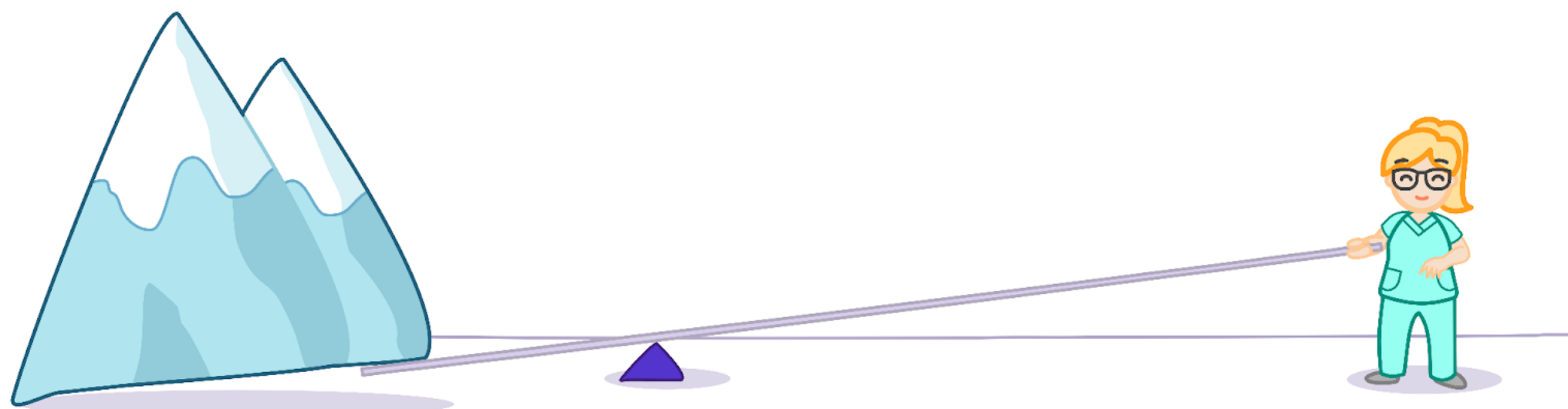

We have mountains to move and we need to work smart.

## Defnyddio'r "system" ac osgoi rhwystrau

### GDPR

Gwrthrych y Data sy'n rheoli rhannu data. Mae hyn yn galluogi sefydliad proffesiynol i "siarad" â chymydog trwy eu cleient/claf heb dorri'r gyfraith.

### Llywodraethu Gwybodaeth Gorfforaethol

Mae gan y Gwasanaethau Cysylltiedig eu system Gofal ac Ymateb eu hunain a sefydliadau yw Rheolydd Data'r system honno. Maent yn rheoli mynediad a gallant barhau i ddilyn eu gweithdrefnau a'u rheolau eu hunain. Hanfodol ar gyfer y GIG a Gwasanaethau Cymdeithasol.

### Dilyn y Safonau

e.e. Rydym yn defnyddio'r Fframwaith Safonau Hyfforddiant Dementia cenedlaethol.

Ei gadw'n syml ac felly'n hawdd ei fabwysiadu.



## Dementia Training Standards Framework

This Framework was commissioned and funded by the Department of Health and developed in collaboration by Skills for Health and Health Education England in partnership with Skills for Care.

This is an updated version of the original 'Dementia Core Skills Education and Training Framework'.



## Fframwaith Safonau Hyfforddiant Dementia

## Using the "system" and avoiding barriers

### GDPR

The Data Subject controls the data sharing. This enables a professional organization to "speak" to a neighbour via their client/patient without breaking the law.

### Corporate Information Governance

Connected Services have their own Care & Respond system and organisations are the Data Controller of that system. They control access and they can continue to follow their own procedures and rules. Essential for NHS and Social Services.

### Follow the Standards

e.g. We use the national Dementia Training Standards Framework.

Keeping it simple and therefore easy to adopt.

# Astudiaethau Achos

wedi'i bweru gan Care and Respond

## Case Studies

powered by Care & Respond



## Atal Gorddos o Gyffuriau Trwy Ddefnyddio Ymateb Cymunedol

Prosiect cydweithio mawr yn targedu'r marwolaethau cynyddol o orddos cyffuriau anghyfreithlon.

### Nodweddion Allweddol:

- Mae ap larwm yn cychwyn yn awtomatig os bydd person yn dod yn anymatebol. Cysylltiad dyfais 3ydd parti dewisol.
- Ap ymateb ffrindiau a theulu
- Ap ymateb elusen allgymorth lleol dewisol
- Ap Rheoli Ambiwllans Dewisol
- Rhybuddion Cynhesu Diogelwch Cyffuriau Cenedlaethol a Lleol – i bob defnyddiwr
- Rheoli gwrthwenwyn naloxone ar gyfer opioidau

### Mae partneriaid yn cynnwys:

- 2 x gwasanaethau ambiwlans
- 4 x elusen cymorth cyffuriau cenedlaethol a lleol
- 1 x Prifysgol

£500k o gyllid gan Swyddfa Gwyddorau Bywyd y DU a Swyddfa Prif Wyddonydd yr Alban

Arddangos yn Senedd yr Alban ym mis Mawrth.

## Drug Overdose Prevention Using a Community Response

A major collaboration project targeting the increasing deaths from illicit drug overdose.

### Key Features:

- Alarm app automatically trigger if a person becomes unresponsive. Optional 3<sup>rd</sup> party device connection.
- Friends and family response app
- Optional local outreach charity response app
- Optional Ambulance Control app
- National and local Drug Safety Warming Alerts – to all users
- Management of naloxone antidote for opioids

### Partners include:

- 2 x ambulance services
- 4 x national and local drug support charities
- 1 x University

£500k funding from the UK Office for Life Sciences and the Scotland's Chief Scientist Office

Showcasing at the Scottish Parliament in March.

## “Yn y Foment” a hyfforddiant dementia pwynt gofal

Defnyddio AI i'n galluogi i ddarparu arweiniad hynod bersonol i ddefnyddwyr yr ap sy'n gofalu am berson â dementia. Gall defnyddwyr fod yn nyrsys, gwasanaethau cymdeithasol, staff cartrefi gofal neu deulu a ffrindiau. Mae'r ap yn defnyddio proffil personol i ddeall taith dementia person, ac yn cyfuno hyn â gwybodaeth gyd-destunol a sefyllfaol i gael cymorth cryno ar unwaith. Ar gyfer gweithwyr proffesiynol, caiff yr hyfforddiant ei olrhain yn llawn i gefnogi nodau hyfforddiant galwedigaethol.

### Nodweddion Allweddol:

- Proffil dementia manwl (wedi'i gwblhau gan ddefnyddiwr neu ddirprwy)
- Deunydd cyngor a hyfforddiant yn seiliedig ar y Fframwaith Safonau Hyfforddiant Dementia cenedlaethol.
- Fideos byr i helpu gofalwr i ddeall y sefyllfa ac i wybod beth i'w wneud. Helpu'r gofalwr i ddeall realiti person.

### Mae cynghorwyr yn cynnwys:

- Arweinwyr mewn dementia yn GIG Cymru; Ambiwylans Cymru; 2 x Bwrdd Iechyd; 1 x Gwasanaethau Cymdeithasol (Gogledd Cymru)

Ariannu gan Ymddiriedolaeth Ufi VocTech (sy'n cefnogi hyfforddiant galwedigaethol ar gyfer grwpiau sydd ag anghenion uchel sy'n cael eu tanwasanaethu) Manylion:

<https://ufi.co.uk/voctech-directory/in-the-moment-and-point-of-care-dementia-training/>

## “In the Moment” and point of care dementia training

Using AI to enable us to provide highly personalized guidance to users of the app who care for a person with dementia. Users can be nurses, social services, care home staff or family and friends. The app uses a personal profile to understand a person's dementia journey, and combines this with contextual and situational information to get immediate bite-sized assistance. For professionals, the training is fully tracked to support vocational training goals.

### Key Features:

- A detailed dementia profile (completed by user or proxy)
- Advice and training material based on the national Dementia Training Standards Framework.
- Short videos to help a carer understand the situation and to know what to do. Helping the carer to understand a person's reality.

### Advisors include:

- Leaders in dementia at NHS Wales; Welsh Ambulance; 2 x Health Boards; 1 x Social Services (N Wales)

Funding by the Ufi VocTech Trust (supporting vocational training for under served groups with high needs) Details:

<https://ufi.co.uk/voctech-directory/in-the-moment-and-point-of-care-dementia-training/>

## Cymorth Iechyd Meddwl “Yn y Foment”

Gellir cymhwyso'r cysyniad “Yn y Foment” i lawer o wahanol sefyllfaoedd ac amodau.

Mae iechyd meddwl gwael yn bryder enfawr sy'n cael effaith aruthrol ar gymdeithas. Cyn bo hir byddwn yn defnyddio ein technoleg i helpu pobl ag iechyd meddwl gwael, ac i helpu eu rhwydwaith cymorth. I ddechrau byddwn yn canolbwyntio ar bobl ifanc, a sut mae iechyd meddwl yn effeithio ar eu cyflogaeth. Yn yr achos hwn bydd y cyflogwr yn helpu i adeiladu'r proffil personol (o safbwynt gwaith) a'r nod yw ymgysylltu'n rhagweithiol ag unigolion a'u rhwydwaith cefnogi cyfan, gan gynnwys eu cyflogwr - cyn bod angen absenoldeb salwch arnynt.

Nodweddion Allweddol:

- Cyfuniad o nodweddion atal ac ymateb o'r ddwy Astudiaeth Achos flaenorol. Ymgorffori ymateb cymunedol; Yn y Foment dysgu; a rheoli iechyd yn rhagweithiol. Mae Gwasanaethau Cysylltiedig yn ddewisol yn cynnwys cyflogwr person a'r GIG.

Mae partneriaid yn cynnwys:

- Elusennau pobl ifanc sydd wedi ennill gwobrau
- Cyflogwr mawr yng Ngogledd Cymru
- Mae Adran Seicoleg Prifysgol.

Cyllid – cyhoeddi diwedd mis Mawrth

## “In the Moment” Mental Health Support

The “In the Moment” concept can be applied to many different situations and conditions.

Poor mental health is a huge concern that is having a massive impact on society. We will shortly be using our technology to help people with poor mental health, and to help their support network. Initially we will be focusing on young people, and how mental health impacts their employment. In this case the employer will be helping to build the personal profile (from a work perspective) and the aim is to proactively engage with individuals and their entire support network, including their employer – before they need sick leave.

Key Features:

- A combination of prevention and response features from the previous two Case Studies. Incorporating community response; In the Moment learning; and proactive health management. Connected Services optionally include a person's employer and the NHS.

Partners include:

- Award winning young people's charities
- A major N Wales employer
- A University Psychology Dept.

Funding – announced late March

## Beth mae ein partneriaid yn ei ddweud

“Grymuso cleifion a theuluoedd i weithredu yw’r cyswllt coll o ran diogelwch cleifion”

Dr Chris Subbe, cynghorydd clinigol  
(Ymgynghorydd mewn Meddygaeth Aciwt, Anadlol a Gofal Dwys,  
Bwrdd Iechyd Prifysgol Betsi Cadwaladr)

“Maen nhw wedi deall pwysigrwydd ymgysylltu â chynulleidfa amrywiol... Mae’r gwelliannau i’w dyluniadau sy’n seiliedig ar fewnwelediadau profi defnyddwyr yn dangos eu bod yn gwrando ac yn gweithredu ar adborth ac yn wirioneddol yn ceisio diwallu anghenion y bobl yr ydym yn ceisio eu cefnogi.”

“Dylid canmol fîm Scenap ar eu gallu i dderbyn mewnwelediad newydd a’u parodrwydd i addasu er mwyn gwneud y mwyaf o effaith a gwerth posibl eu datrysiad arfaethedig.

Rydym yn cytuno’n llwyr â’u myfyrdodau... ac yn gyffrous iawn am y cyfle i adeiladu ecosystem integredig o gymorth ar gyfer pobl sydd mewn perygl o orddos o gyffuriau, yn hytrach na datblygu technoleg siled a fydd yn anodd ei gweithredu ac efallai mai dim ond newid cyfyngedig yn y byd go iawn sy’n cael ei gyflawni. Mae’r ffaith bod gwasanaethau a arweinir gan y gymuned mor barod i ddefnyddio’r gwasanaeth arfaethedig yn hynod gadarnhaol.”

“Mae Scienap wir yn deall yr her sydd wrth law...”, Cyfarwyddwr Arloesedd y Gwasanaeth Ambiwlans.

## What our partners say

“Empowering patients and families to take action is the missing link in patient safety”

Dr Chris Subbe, clinical advisor  
(Consultant in Acute, Respiratory & Intensive Care Medicine,  
Betsi Cadwaladr University Health Board)

“They have understood the importance of engaging a diverse audience...

The refinements to their designs based on user testing insights shows that they are both listening and acting on feedback and truly trying to meet the needs of the people we are trying to support.”

“The Scienap team should be commended on their ability to take on board new insight and their willingness to adapt in order to maximise the potential impact and value of their proposed solution.

We fully agree with their reflections... and are very excited about the opportunity to build an integrated ecosystem of support for people who are at risk of drug overdose, rather than build siloed technology that will be hard to implement and may only deliver limited real world change. The fact that community led services are so willing to use the proposed service is extremely positive.”

“Scienap truly understands the challenge at hand...”, an Ambulance Service Innovation Director.

## **Diolch yn fawr!**

**Rydym yn ffynnu ar gydweithio. Cysylltwch â ni os oes angen help arnoch gyda'ch arloesedd digidol.  
James.Ingram@scienap.com**

## **Thank you!**

**We thrive on collaboration. Please contact us if you need help with your digital innovation.  
James.Ingram@scienap.com**



# Trafodaeth Banel

## Panel Discussion

Aimee Twinberrow  
Innovation Lead, Social Care Wales